



Quick Start Guide

Flow Demo Board

FS5/FS7, OOL

Front side of Flow Demo Board:

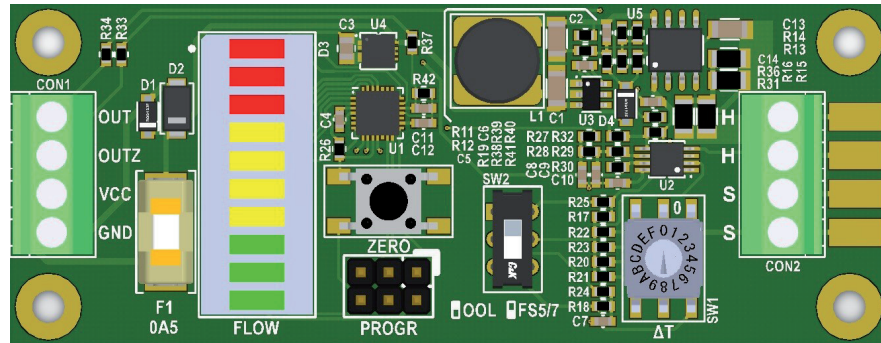

Back side of Flow Demo Board:

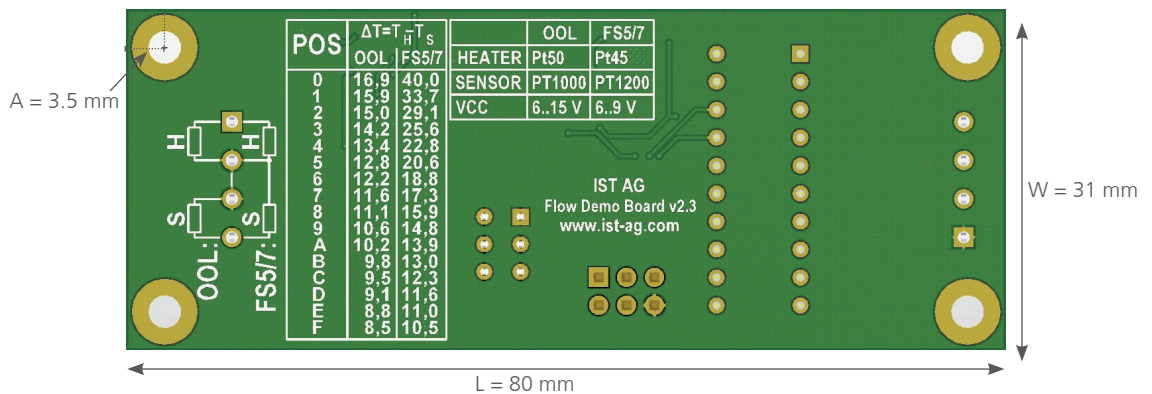

How to connect PCB:

- For OOL sensor move switch to "OOL" position, for FS5 or FS7 sensor to "FS5/7" position.
- Connect the sensor to CON2 terminals according to the diagram on back of PCB: Heater to terminals "H", temperature sensor to terminals "S" (screw or solder them directly to pads). For FS5 or FS7 sensor please connect sensor's common wire to one of the middle terminals of CON2.
- Select desired difference of temperatures between heater and temperature sensor using ΔT switch and the table on back of the PCB.
- Connect power supply to CON1: positive to "VCC", negative to "GND". For OOL sensor no more than +15 V, for FS5/7 no more than +9 V.
- Connect voltmeter to CON1: positive to "OUT" or "OUTZ", negative to "GND".
- Switch on power supply.
- For zero flow press "ZERO" button in order to subtract zero flow offset from LED bar and "OUTZ" output, note that "OUT" output will remain unaffected.
- The OOL sensor is directional, flow's direction should be: from temperature sensor to heater.



Wiring for OOL Sensor:

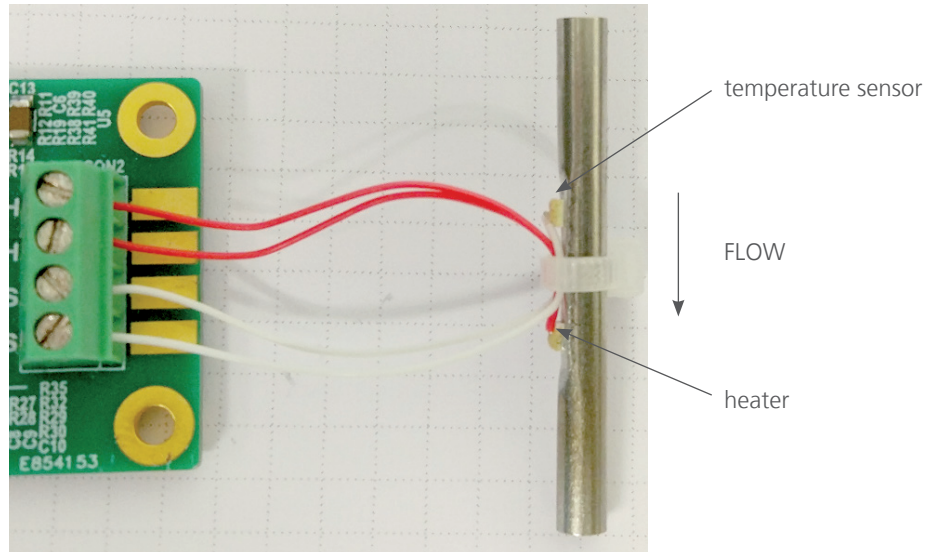

Wiring for FS5/FS7 Sensor:

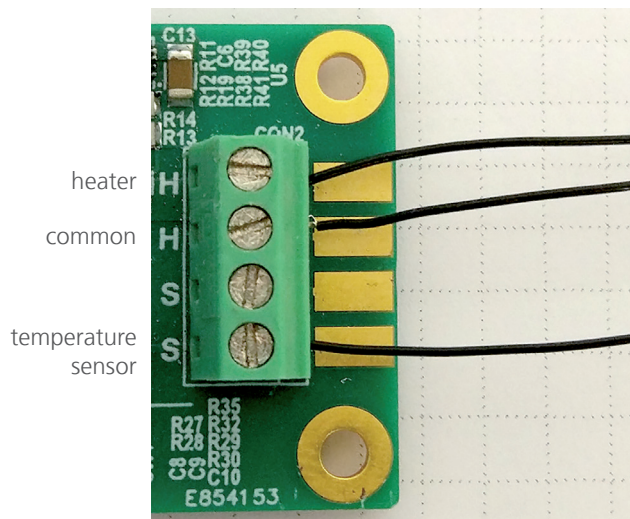
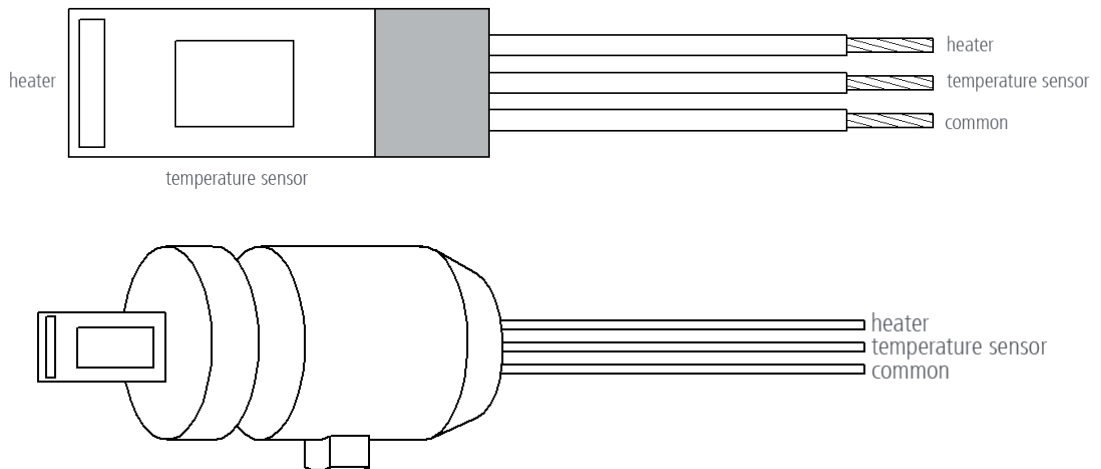



How the PCB works:

- The PCB measures flow using the Constant Temperature Anemometer (CTA) principle.
- During normal operation CTA will always keep the temperature of the heater (T_H) above the temperature of the sensor (T_S) by a constant, predefined value $\Delta T = T_H - T_S$.
- The CTA is made using an analog Wheatstone Bridge with simplified diagram:

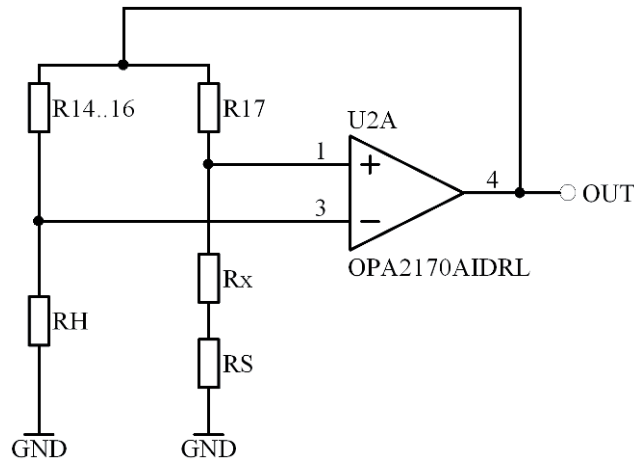

- PCB's output voltage "OUT" is connected to the bridge.
- Additionally, the PCB has the "OUTZ" output allowing the user to measure flow without zero flow offset (zero flow = zero volts).
- Maximum power dissipated in the sensor / maximum "OUT" voltage can be limited using supply voltage: $U_{OUT(max)} = VCC - 2V$. Maximum VCC current should not exceed 0.4 A.
- The PCB is protected using 0.5 A fuse F1, if PCB does not respond please check the fuse.
- The total value of R14..16 sensors is 21 Ω , for OOL sensor R17 = 420 Ω while for FS5/7 sensor R17 = 560 Ω .
- Please note that the Flow Demo Board ist not temperature-compensated.

Typical characteristics

FS7 Sensor:

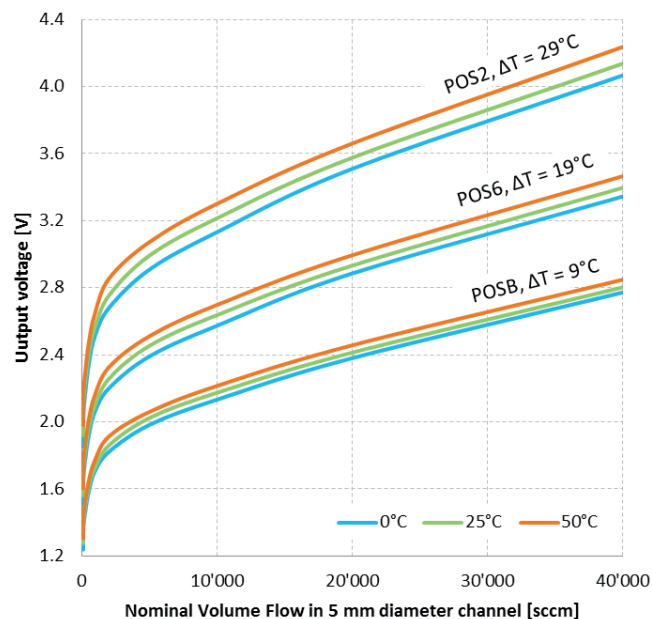



OOL Sensor:

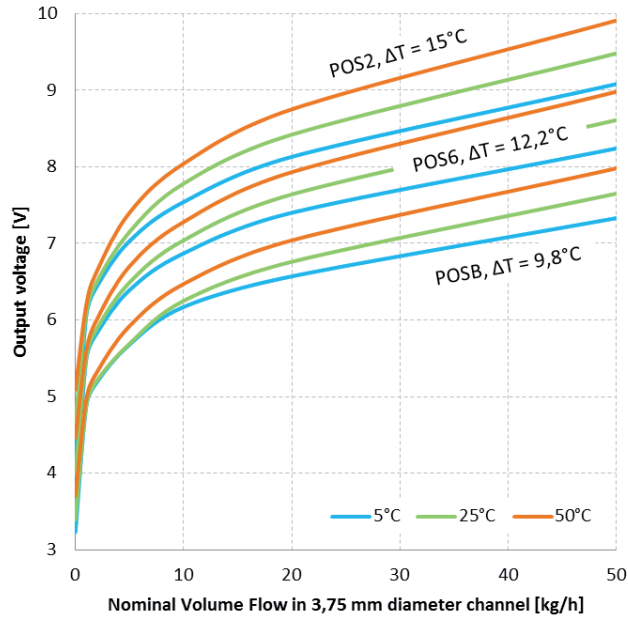

Order Information

Order Code / Former order code:

108327	Board without sensor
104018 / 160.00023	Board with F57 sensor (with housing)
104019 / 160.00024	Board with 6 mm Out of Liquid sensor
104021 / 160.00026	Board with 4 mm Out of Liquid sensor
104022 / 160.00027	Board with Real Probe sensors

Additional Documents

	Document name:
Data Sheet:	DFFS5_E DFFS7_E DFOOL_E DF_Demo_Board_E
Application Note:	AFFS5_E AFFS7_E